

# Technical Data

Booster set name

1GPE MATRIX 3-6T/0.9 ESPM

Customer	Date 05.04.2024	Company
Contact	Item no.	Issued by
Phone	Project	Phone
E-mail	Project ID	E-mail

## Requested data

1	Pump type	Booster Set	Fluid	Water
2	Number of pumps	1	Liquid temperature °C	20
3	Flow m <sup>3</sup> /h		Kin. viscosity cSt	1.005
4	Head m		Vapour pressure kPa	2.34
5	Geodetic head m		PH value	
6	Inlet pressure kPa	0	Density kg/m <sup>3</sup>	998.3
7	Available system NPSH	Ask our technical department.	Solids Weight %	0
8	Ambient temperature °C	20	Installation height m	100

## Booster Set

9	Booster set name	1GPE MATRIX 3-6T/0.9 ESPM	Frequency Hz	50
10	Design	Booster Set		
11	Manufacturer		Impeller Dia.	Max. mm 99
12	Speed rpm	2850		Designed mm 99
13	No. of Stage	6		Min. mm 99
14	Connection Suction side	G1 F PN10	Flow	Operating m <sup>3</sup> /h
15	Connection Discharge side	G1 F PN10		Max- m <sup>3</sup> /h 4.8
16	Max Working Pressure kPa	1000		Min- m <sup>3</sup> /h 1.2
17	Shut-off head kPa	663.85	Head	Operating m
18	Total weight kg	See the table of "Dimensions".		- (Qmax.) m 24.0
19	Shaft power kW			- (Qmin.) m 62.7
20			Max. Shaft Power at max. impeller kW	0.88
21	Required NPSH m		Efficiency %	

## Materials

22	Check valve	AISI 304/Silicone	O-ring	EPDM
23	Impeller	AISI 304		
24	Casing	AISI 304		
25	External pump casing	AISI 304		
26	Shaft	AISI 304		
27	Shaft seal	Ceramic/Carbon/EPDM		

## Motor

28	Manufacturer	EPE Standard	Insulation class	F
29	Type	TEFC_MATRIX 3-6T/0.9_230_Three Phase	Phases	3~
30	Specific design	IE3 / 50 Hz / Pole pairs 1	Frame size	
31	Rated power kW	0.9	Weight; motor kg	
32	Number of poles	2	Electric voltage V	230
33	Speed rpm	2850	Electric current A	4.3
34	Degree of protection	IP 55		
35				

## Remarks

# Performance curve

Booster set name

1GPE MATRIX 3-6T/0.9 ESPM

Customer	Date 05.04.2024	Company
Contact	Item no.	Issued by
Phone	Project	Phone
E-mail	Project ID	E-mail

**Requested data**

1	Flow	m³/h	
2	Head	m	
3	Geodetic head	m	

**Booster set**

Operating flow	m³/h	Frequency	Hz	50
Operating head	m	Number of poles		2
ImpellerDiameter Designed	mm	99	Speed	rpm 2850

Test standard: ISO 9906:2012 - Grade3B

Water; 20°C; 998.3kg/m³; 1cSt

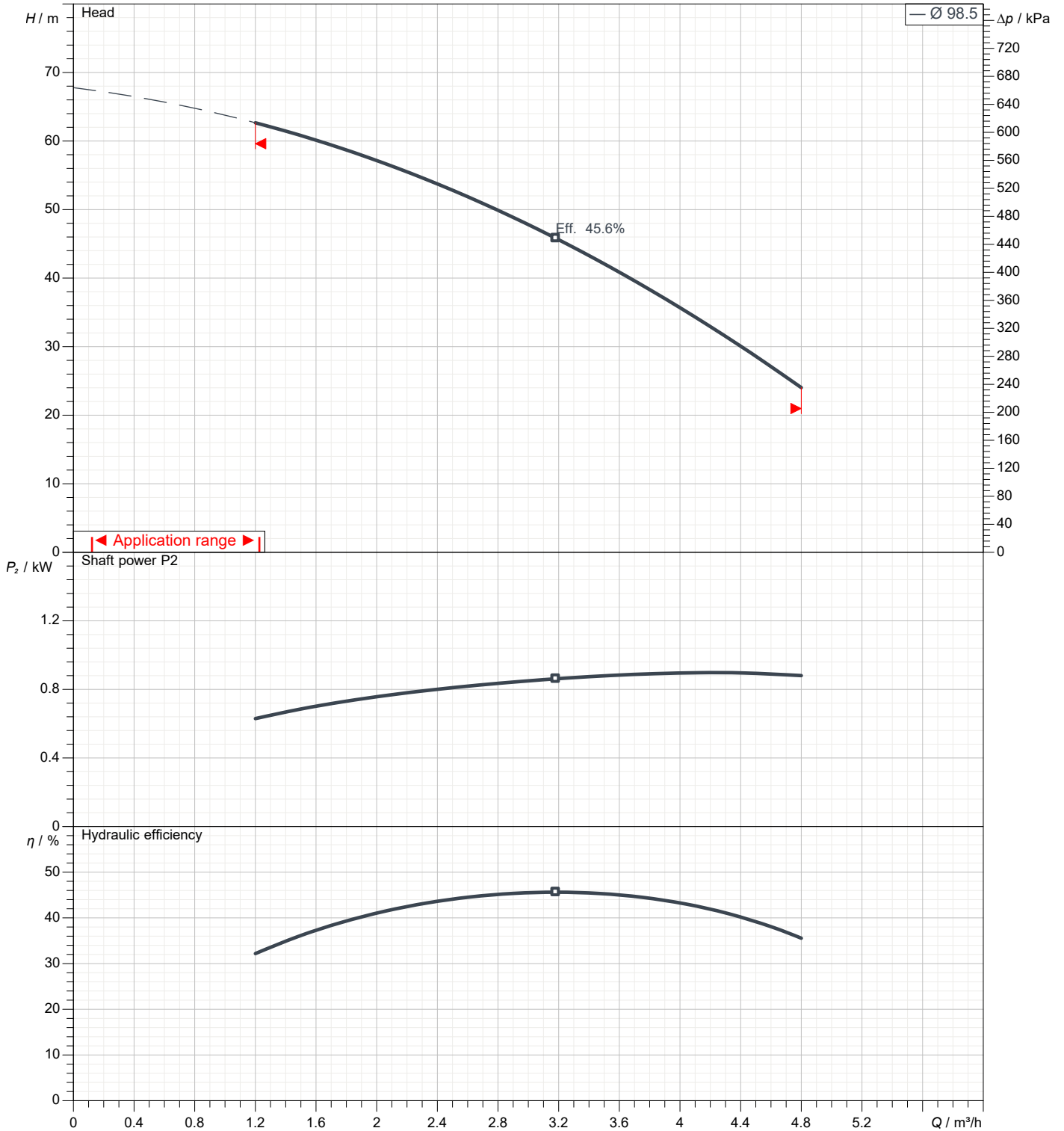

# Dimensions

Booster set name

1GPE MATRIX 3-6T/0.9 ESPM

Customer	Date 05.04.2024	Company
Contact	Item no.	Issued by
Phone	Project	Phone
E-mail	Project ID	E-mail

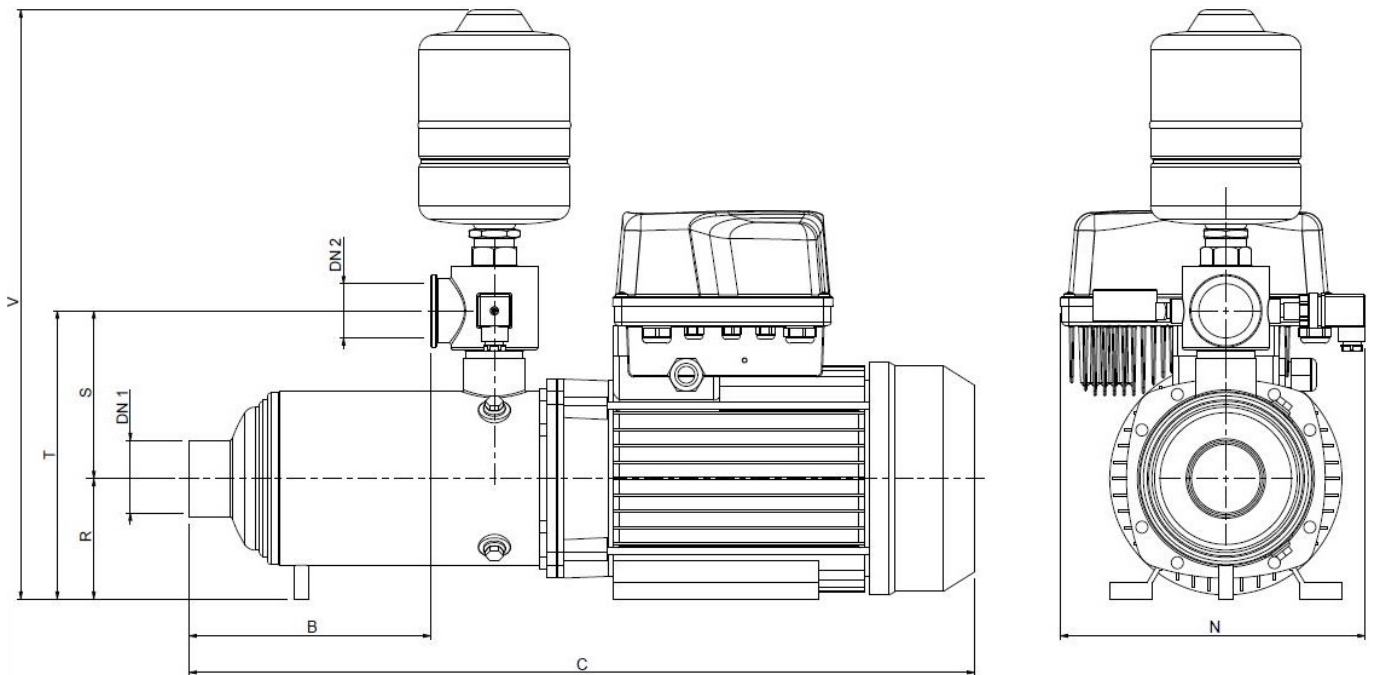

Dimensions in		mm						
1	B	125						
2	C	444						
3	DN1	G1 F						
4	DN2	G1 F						
5	N	243						
6	R	90						
7	S	133						
8	T	223						
9	V	461						
10	Weight kg	18.1						
11								
12								
13								
14								
15								

# (1/2) Construction

Booster set name

1GPE MATRIX 3-6T/0.9 ESPM

Customer	Date 05.04.2024	Company
Contact	Item no.	Issued by
Phone	Project	Phone
E-mail	Project ID	E-mail

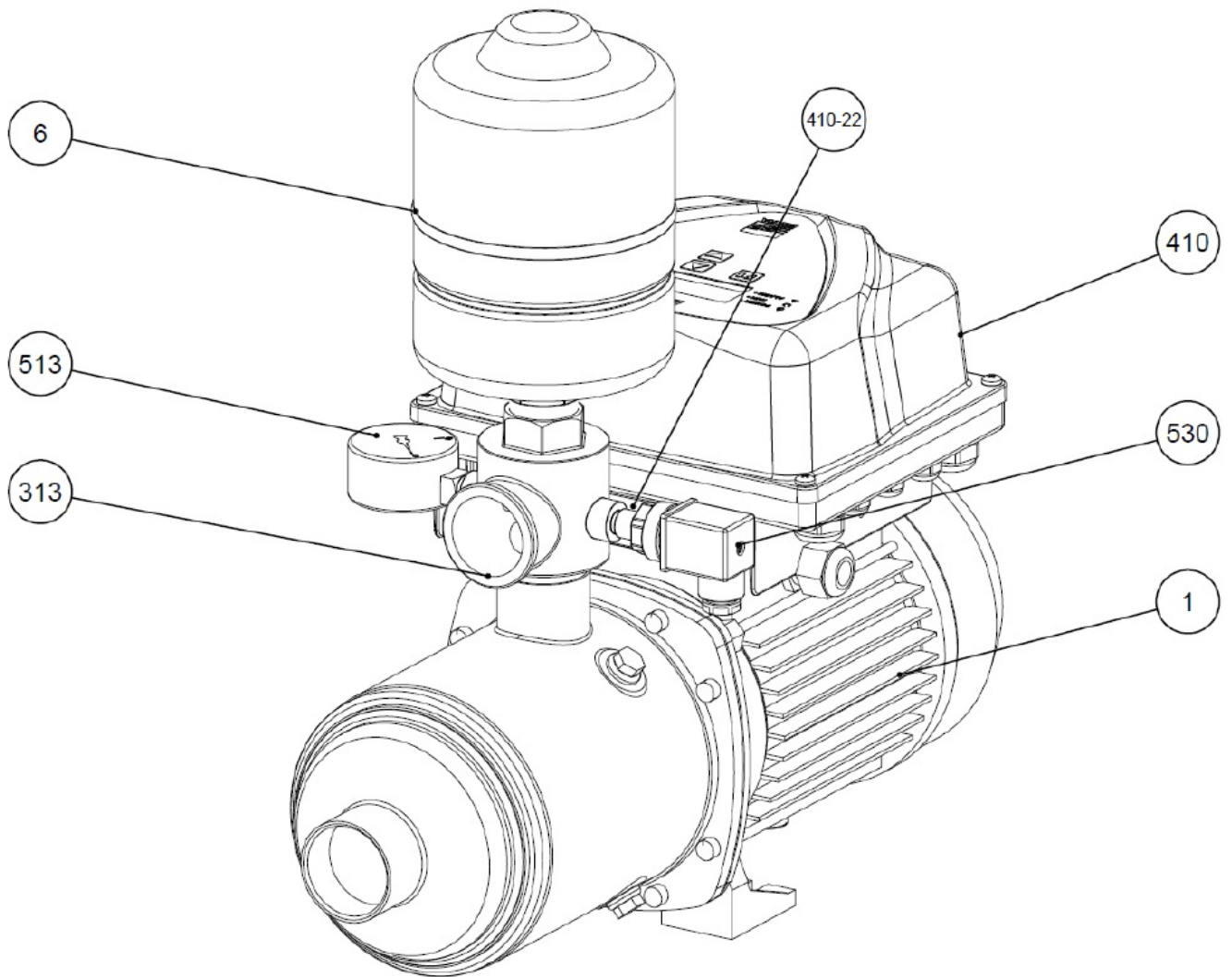

N°	PART NAME	MATERIAL	Quantity
1	Electropump	-	1
6	Membrane Vessel	-	1
313	5-Way Check Valve	AISI 304	1
410	E-SPD+	-	1
410-22	E-SPD+ adaptor	-	1
513	Pressure gauge	Copper alloy / plastic	1
530	Pressure transmitter	-	1

**(2/2)**  
**Construction**

**Booster set name**  
**1GPE MATRIX 3-6T/0.9 ESPM**

Customer	Date 05.04.2024	Company
Contact	Item no.	Issued by
Phone	Project	Phone
E-mail	Project ID	E-mail

**MECHANICAL SEAL**

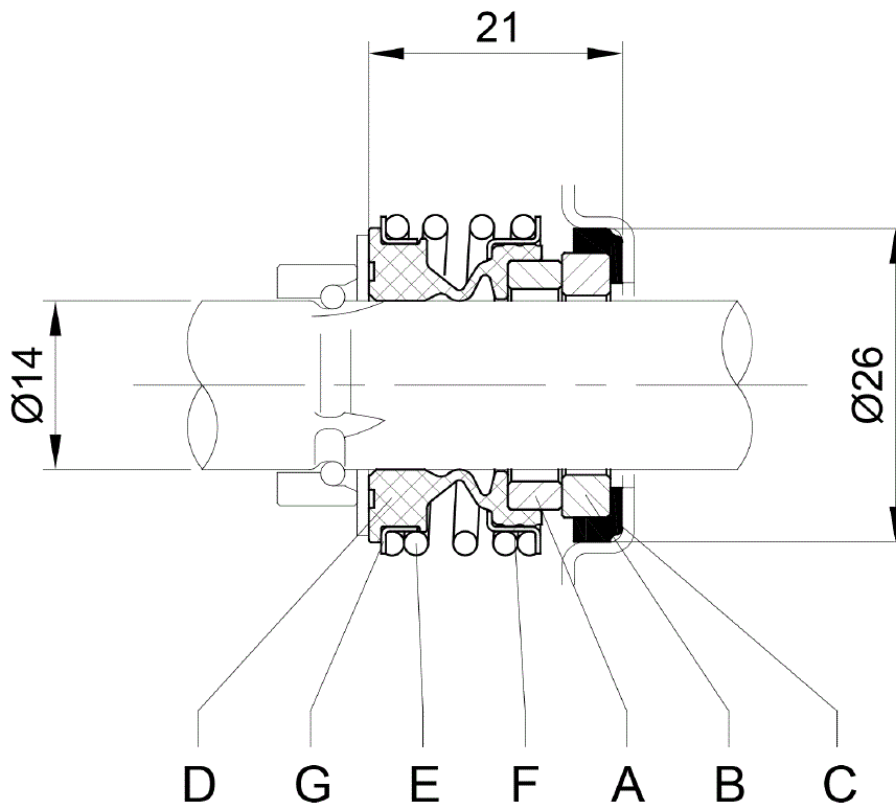

	A	B	C	Material			
	Rotary seal ring	Stationary seal ring	Gasket	D Bellows	E Spring	F Frame	G Retainer ring
<b>STANDARD*</b>	Carbon	Ceramic	EPDM	EPDM	EN 1.4402 (AISI 316)	EN 1.4402 (AISI 316)	EN 1.4402 (AISI 316)

\*Approval for drinking water application  
WRAS Approval product

