

Technical Data

Booster set name

3GPE MATRIX 10-6T/2,2 ESPM (UK)

Customer	Date	05.04.2024	Company
Contact	Item no.		Issued by
Phone	Project		Phone
E-mail	Project ID		E-mail

Requested data

1	Pump type	Booster Set	Fluid	Water
2	Number of pumps	3	Liquid temperature	°C 20
3	Flow	m ³ /h	Kin. viscosity	cSt 1.005
4	Head	m	Vapour pressure	kPa 2.34
5	Geodetic head	m	PH value	
6	Inlet pressure	kPa 0	Density	kg/m ³ 998.3
7	Available system NPSH	Ask our technical department.	Solids	Weight % 0
8	Ambient temperature	°C 20	Installation height	m 100

Booster Set

9	Booster set name	3GPE MATRIX 10-6T/2,2 ESPM (UK)	Frequency	Hz 50	
10	Design	Booster Set			
11	Manufacturer		Impeller Dia.	Max.	mm 101
12	Speed	rpm 2850		Designed	mm 101
13	No. of Stage	6		Min.	mm 101
14	Connection	Suction side UNI ISO 228 PN16	Flow	Operating	m ³ /h
15	Connection	Discharge side UNI ISO 228 PN16		Max-	m ³ /h 15
16	Max Working Pressure	kPa 1000		Min-	m ³ /h 3.6
17	Shut-off head	kPa 706.52	Head	Operating	m
18	Total weight	kg See the table of "Dimensions".		- (Qmax.)	m 17.2
19	Shaft power	kW		- (Qmin.)	m 66.5
20			Max. Shaft Power at max. impeller	kW 2.28	
21	Required NPSH	m	Efficiency	%	

Materials

22	Frame	Galvanized steel	External pump casing	AISI 304
23	Manifold	AISI 304	Shaft	AISI 304
24	Check valve	Brass / NBR	Shaft seal	Ceramic/Carbon/EPDM
25	Ball valve	Brass / PTFE	O-ring	EPDM
26	Impeller	AISI 304		
27	Casing	AISI 304		

Motor

28	Manufacturer	EPE Standard	Insulation class	F
29	Type	TEFC_MATRIX 10-6T/2,2_230_Three Phase	Phases	3~
30	Specific design	IE3 / 50 Hz / Pole pairs 1	Frame size	
31	Rated power	kW 2.2	Weight; motor	kg
32	Number of poles	2	Electric voltage	V 230
33	Speed	rpm 2850	Electric current	A 8.2
34	Degree of protection	IP 55		
35				

Remarks

Item intended for the UK market only.

Performance curve

Booster set name

3GPE MATRIX 10-6T/2,2 ESPM (UK)

Customer	Date	05.04.2024	Company
Contact	Item no.		Issued by
Phone	Project		Phone
E-mail	Project ID		E-mail

Requested data

1	Flow	m³/h	
2	Head	m	
3	Geodetic head	m	

Booster set

Operating flow	m³/h		Frequency	Hz	50
Operating head	m		Number of poles		2
ImpellerDiameter Designed	mm	101	Speed	rpm	2850

Test standard: ISO 9906:2012 - Grade3B

Water; 20°C; 998.3kg/m³; 1cSt

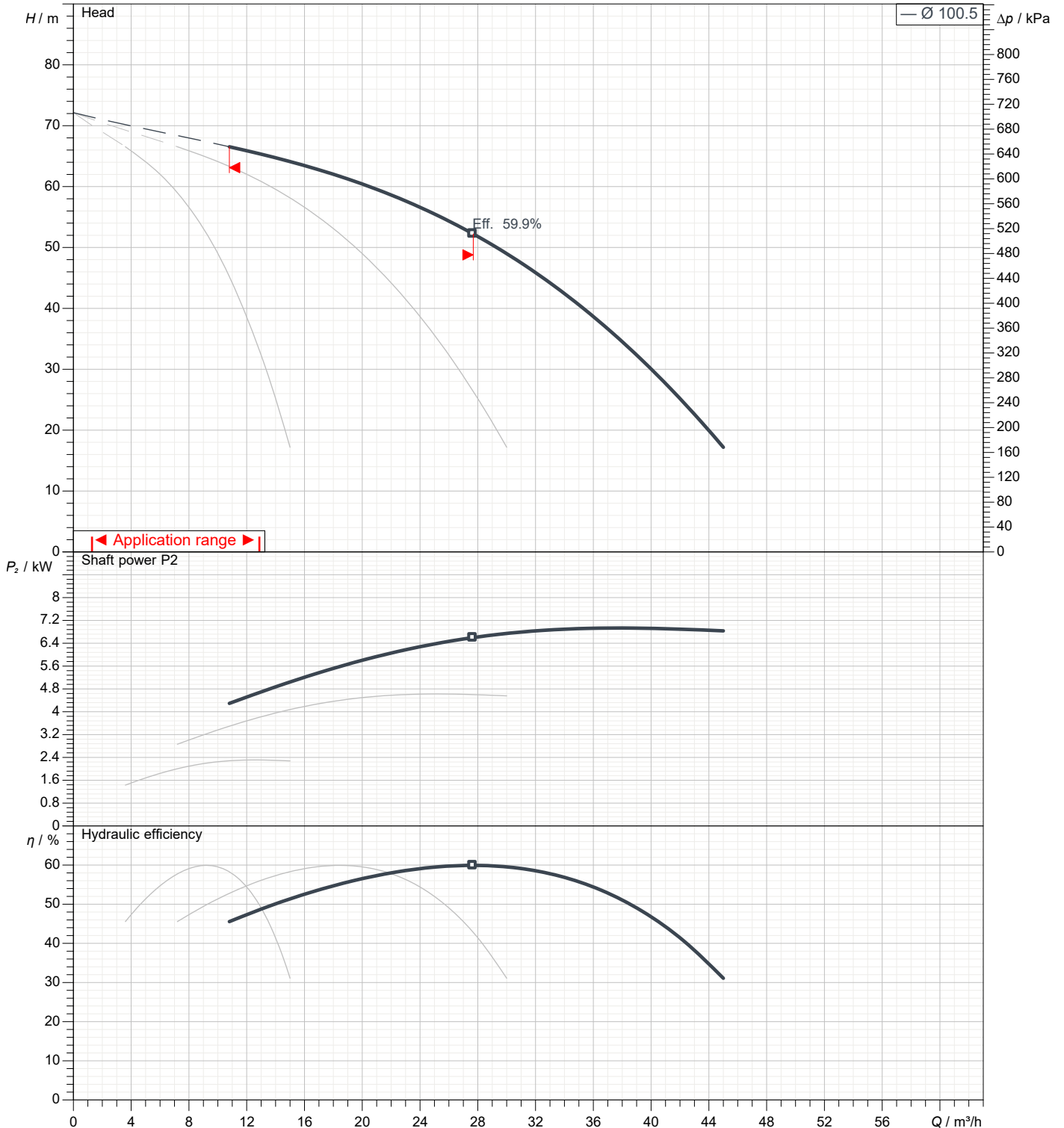

Dimensions

Booster set name

3GPE MATRIX 10-6T/2,2 ESPM (UK)

Customer	Date 05.04.2024	Company
Contact	Item no.	Issued by
Phone	Project	Phone
E-mail	Project ID	E-mail

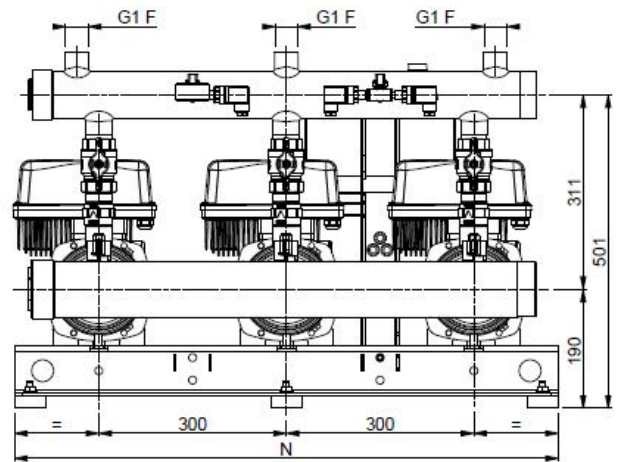
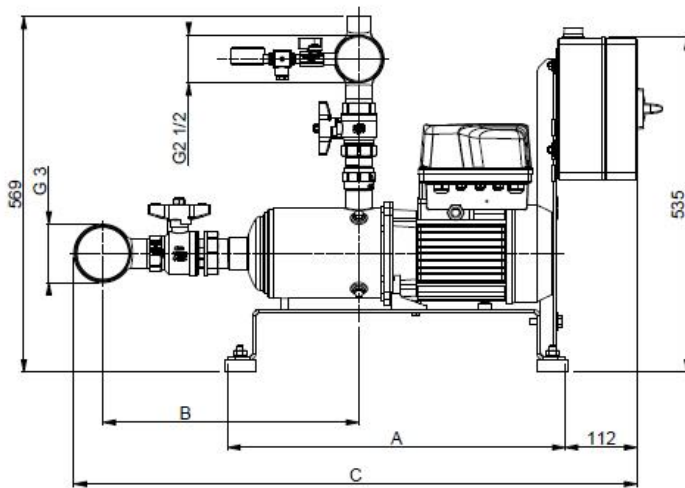

Dimensions in		mm						
1	A	540						
2	B	410						
3	C	900						
4	N	870						
5	Weight kg	114						
6								
7								
8								
9								
10								
11								
12								
13								
14								
15								

(1/2) Construction

Booster set name

3GPE MATRIX 10-6T/2,2 ESPM (UK)

Customer	Date 05.04.2024	Company
Contact	Item no.	Issued by
Phone	Project	Phone
E-mail	Project ID	E-mail

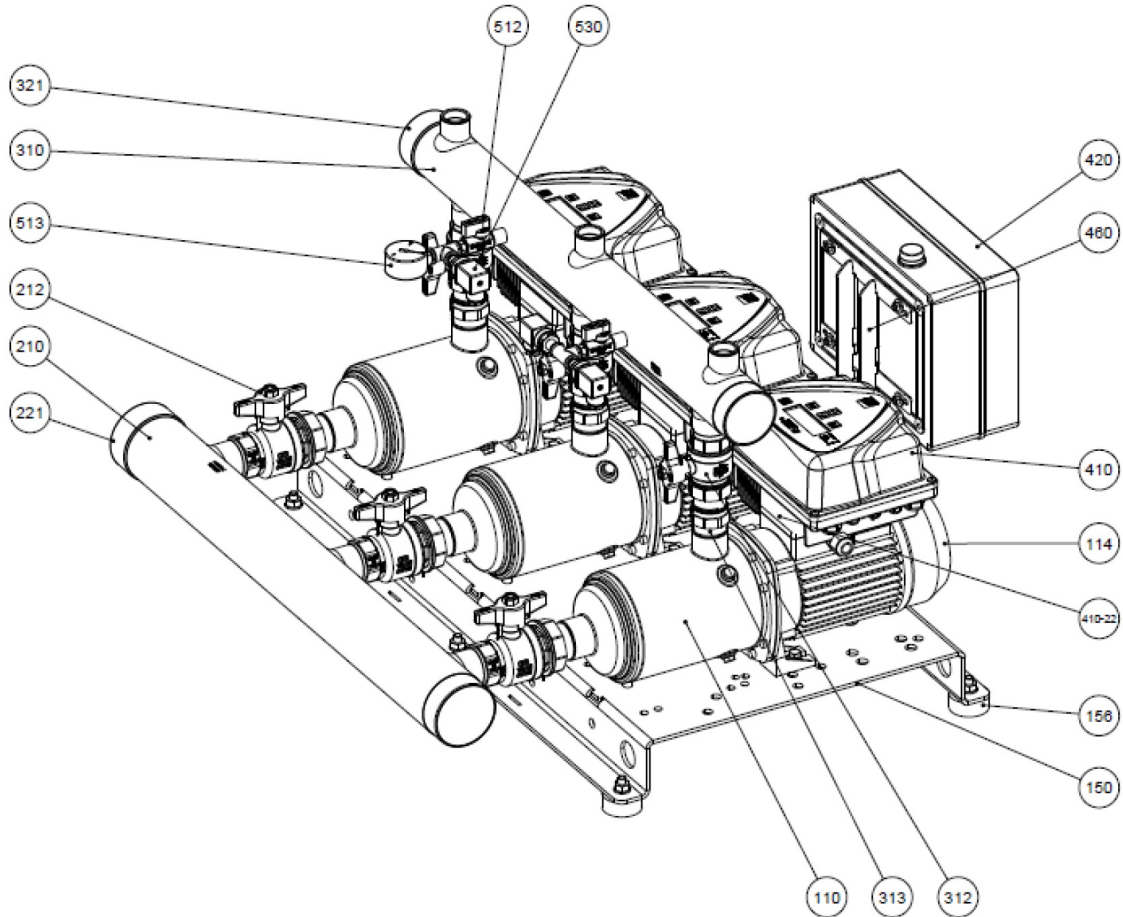

N°	PART NAME	MATERIAL	Quantity
110	Principal pump	-	3
114	Electric motor	-	3
150	Baseplate	Galvanized steel	1
156	Baseplate foot	SBR	6
210	Suction manifold	AISI 304	1
212	Union ball valve	Brass / P.T.F.E.	3
221	Threaded female cap	AISI 304	1
310	Discharge manifold	AISI 304	1
312	Union ball valve	Brass / P.T.F.E.	3
313	Check valve	Brass / NBR	3
321	Threaded female cap	AISI 304	1
410	E-SPD+	-	3
410-22	E-SPD+ adaptor	-	3
420	Protection panel	-	1
460	Protection panel frame	Galvanized steel	1
512	Ball valve	Brass / P.T.F.E.	2
513	Pressure gauge	Copper alloy / plastic	1
530	Pressure transmitter	-	3

(2/2)
Construction

Booster set name
3GPE MATRIX 10-6T/2,2 ESPM (UK)

Customer	Date 05.04.2024	Company
Contact	Item no.	Issued by
Phone	Project	Phone
E-mail	Project ID	E-mail

MECHANICAL SEAL

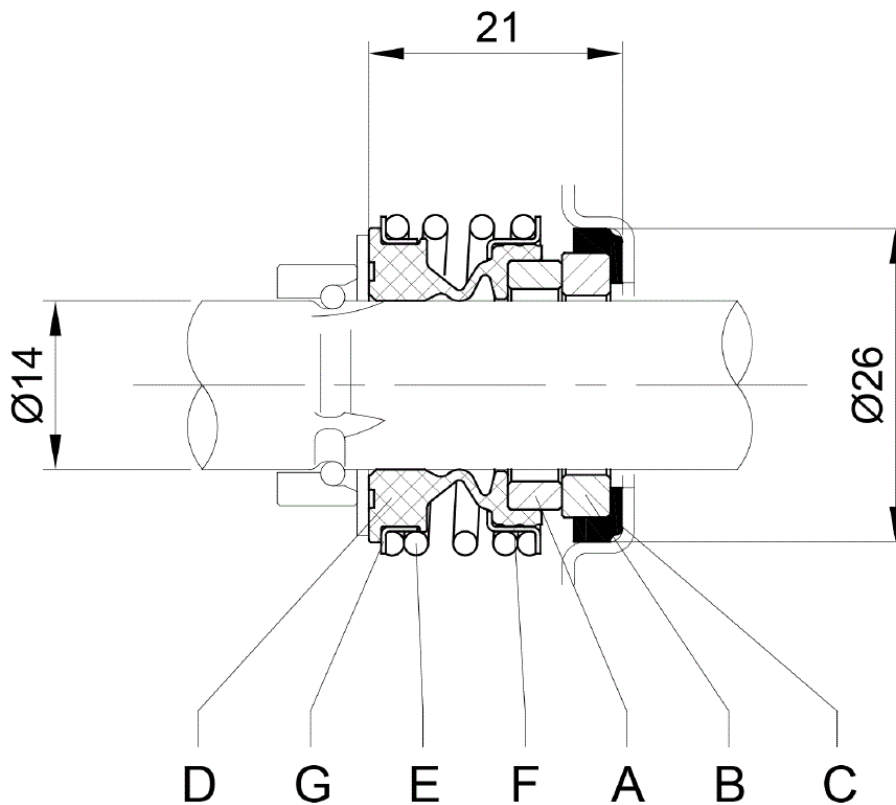

	A	B	C	Material	E	F	G
	Rotary seal ring	Stationary seal ring	Gasket	D Bellows	Spring	Frame	Retainer ring
STANDARD*	Carbon	Ceramic	EPDM	EPDM	EN 1.4402 (AISI 316)	EN 1.4402 (AISI 316)	EN 1.4402 (AISI 316)

*Approval for drinking water application
WRAS Approval product

